



Dough Mixers 10 liter Spiral Dough Kneader, 1 Speed

ITEM # _____

MODEL # _____

NAME # _____

SIS # _____

AIA # _____



602282 (DSK10L)

10 Lt spiral Dough Kneader, 1 speed (tool speed 88 rpm), on wheels

Short Form Specification

Item No. _____

Spiral dough kneader on wheels for pizzerias, bakeries and pastries. Ingredients are kneaded with a stainless steel spiral mixer arm synchronised with bowl rotation (motorized not removable bowl). Body is in painted steel, the 10 Lt capacity bowl, the spiral mixer arm and dough breaker pin are in stainless steel. The safety screen allows ingredients to be added without stopping the machine. Equipped with a low voltage control panel with buttons and safety device to stop the machine when the protection screen is opened. 1 speed= 88 rpm - spiral arm, 10 rpm - bowl. Maximum kneading capacity: 8 kg per cycle (max flour 5kg/cycle), with 60% hydration.

Main Features

- Spiral dough kneader with motorized bowl (not removable) and fixed head.
- Ideal for kneading pizza dough, bread or similar dough.
- One speed kneading (tool speed: 88 rpm, bowl speed: 10 rpm).
- Stainless steel (AISI304) squared dough breaker bar for fast and even kneading results
- Maximum kneading capacity: 8 kg per cycle (max flour 5kg/cycle), with 60% hydration.
- Minimum kneading capacity: 5 kg/cycle, with 60% hydration.
- Safety device stops the appliance if the cover is openend.
- Equipped with 4 wheels, of which 2 with brakes, allowing to easily move the appliance for storage or cleaning.
- The appliance fits under standard kitchen worktops (see installation drawing).

Construction

- Constructed in painted steel.
- AISI304 stainless steel bowl, spiral hook and dough breaker bar.
- IP54 protected control panel.
- IP23 for the appliance overall.
- Plug as standard (schuko type).

APPROVAL: _____



Dough Mixers 10 liter Spiral Dough Kneader, 1 Speed

Side

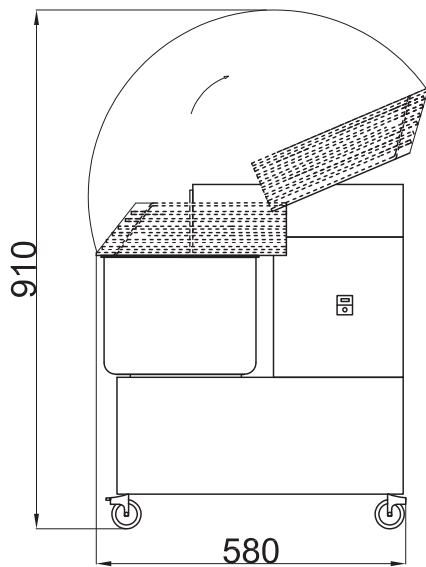

Electric

Supply voltage: 220-240 V/1N ph/50 Hz
Electrical power, default: 0.37 kW

Capacity:

Maximum kneading (60% hydration): 8 kg/Cycle

Key Information:

External dimensions, Width: 300 mm

External dimensions, Depth: 550 mm

External dimensions, Height: 620 mm

Shipping weight: 49 kg

Bowl capacity: 10 lt

Front

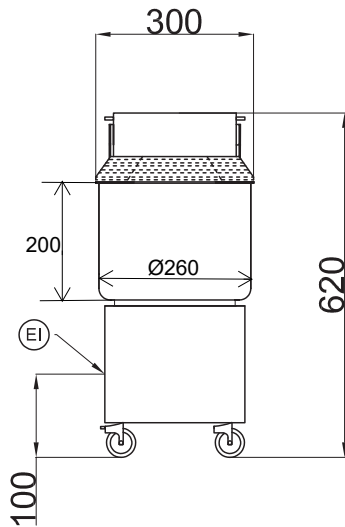

EI = Electrical inlet (power)

Top

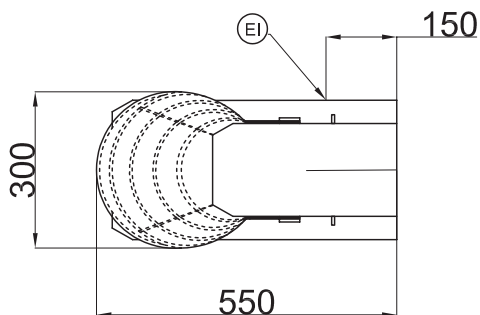

Dough Mixers
10 liter Spiral Dough Kneader, 1 Speed

The company reserves the right to make modifications to the products without prior notice. All information correct at time of printing.



2026.03.24